



YEALINK T54W USER GUIDE

TABLE OF CONTENTS

T54W Quick Start Guide	3
Guided Setup	4
Connecting handset and optional headset.....	4
Connecting cables	5
Connecting to Wi-Fi.....	6
Voicemail Box Setup	8
Recording your personal voicemail greeting	8
Changing the PIN from the phone	8
Commonly Used Features.....	9
Placing outgoing calls	9
Answering an incoming call	9
Rejecting an incoming call.....	9
Ignoring an incoming call	10
Ending a call	10
Hold.....	10
Mute.....	10
Voicemail	10
Transferring Calls	11
Call waiting.....	11
Volume adjustment.....	11
Speakerphone	12
Forwarding calls	12
Customer Support.....	13
Notes	14

T54W QUICK START GUIDE



Soft Keys Select keys that display along the bottom of the screen

Mute/Unmute Mutes and unmutes audio during calls

Headset Place and receive calls through a headset

Voicemail Access voicemail messages

Redial Dial the last called number or extension

Speakerphone Place and receive calls using the speakerphone

Keypad Enter numbers, letters and special characters; select index numbers on menu items

Volume Adjust the volume of handset, headset and speaker

Cancel Holds an active call or resumes a held call

Navigation Scroll through information or options on the screen

Line Keys Select phone line, view calls on a line or quickly call a favorite contact

Transfer Transfer a call to a different number or extension

Hold Place or resume a call on hold

GUIDED SETUP

Attach the stand and adjust the angle of the screen, as shown below:

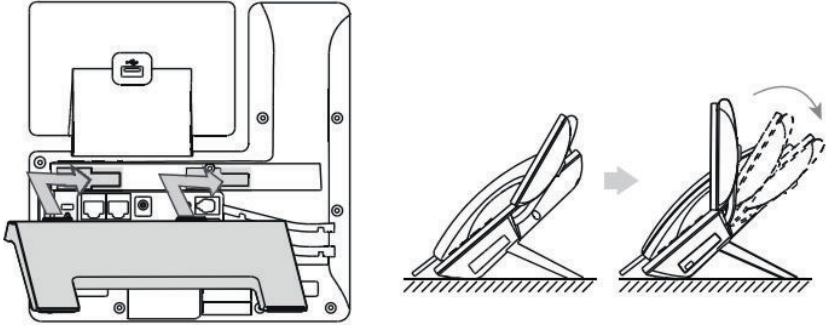

Connecting handset and optional headset

Your phone supports headsets using an RJ9 cable. For connection directions, refer to your headset documentation.

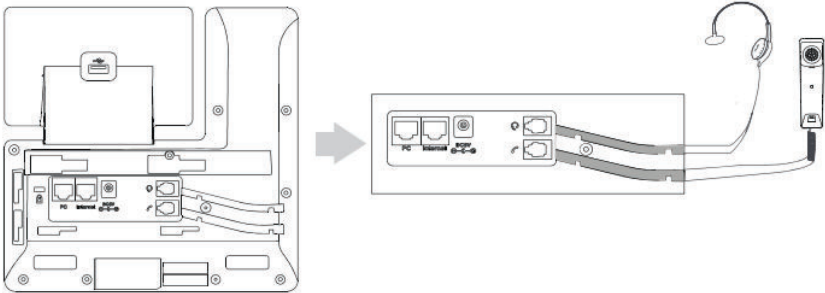

Connecting cables

Follow the diagram below to install your phone. Once plugged in, the phone will automatically download its configuration and begin to work. The voicemail box will be functional with a default greeting.

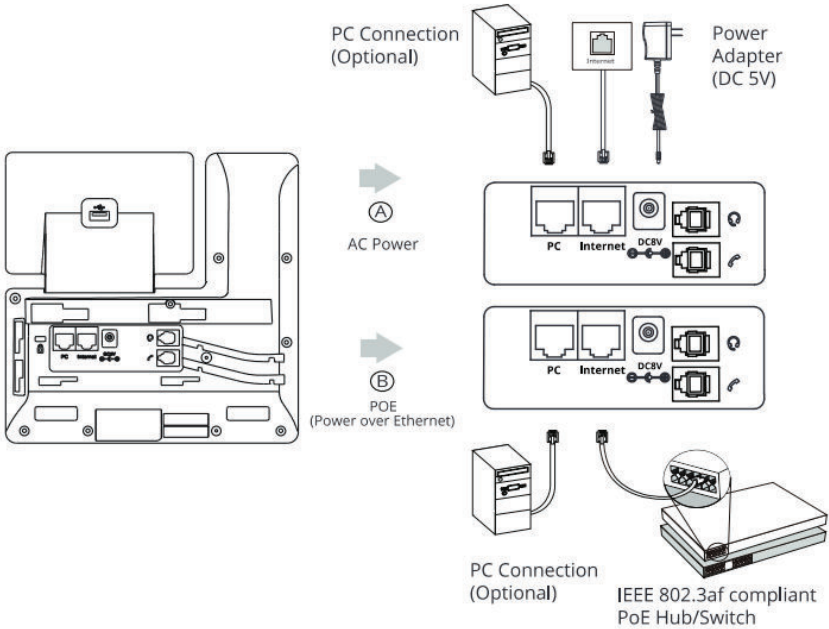

CONNECTING TO WI-FI

1. Press **Menu**.
2. Select **Settings** then press **Enter**.
3. Select **Basic Settings** then press **Enter**.
4. Scroll to **Wi-Fi** then press **Enter**.
5. Select **Wi-Fi**, toggle it **On** and press **Save**.
6. Press **OK** once the Wi-Fi adapter is recognized to start scanning for available Wi-Fi networks.

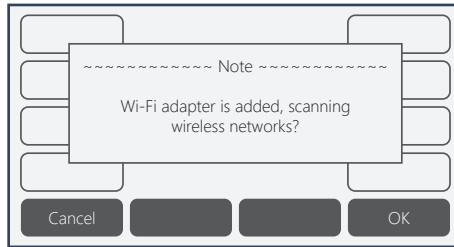

Your phone will list all available Wi-Fi networks it has identified.

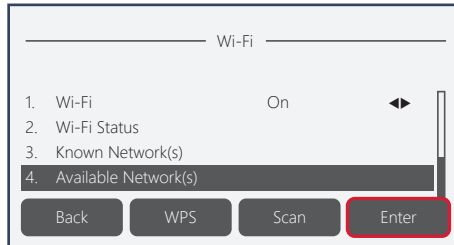

7. Press the **Enter** softkey.
8. Use the navigation arrows to highlight the network you would like to connect to. Press the **Connect** softkey.

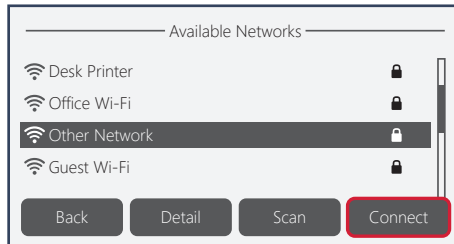

9. Enter the Wi-Fi network password.

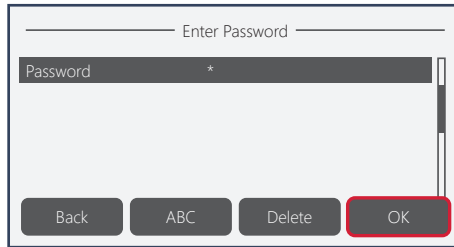

Use the softkeys and keypad to toggle between uppercase and lowercase letters as you enter each character. For example, enter lowercase **b** by pressing the **ABC** softkey until it displays **abc** then press the 2 key in the keypad twice.

To erase incorrect characters, simply press the Delete softkey.

NOTE: Special characters are under the **Star (*)** button.

10. Press **OK** once you have entered the password to connect to the Wi-Fi network.

Your phone will remember this connection as a Known Network. Once the phone is connected and fully updated, you will see the date, time and username displayed on the screen. You are now able to make calls.

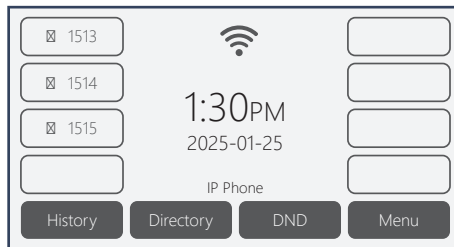

VOICEMAIL BOX SETUP

Recording your personal voicemail greeting

1. Press the **Messages**  button.
2. Enter the PIN provided to you by your Administrator followed by the # key.
3. Select **option 3** for personal options.
4. Select **option 1** to record your voicemail greeting.
5. Follow the voice prompts to record and check your greeting.

Changing the PIN from the phone

1. Press the **Messages**  button.
2. Enter the PIN provided to you by your Administrator, followed by the # key.
3. Select **option 3** for personal options.
4. Select **option 2** to change your PIN.
5. Enter the new PIN when prompted. Press the # key when done.

COMMONLY USED FEATURES

Placing outgoing calls

When the phone is not in use:

1. Pick up the handset or press the **Speakerphone**  button.
2. Dial tone will be heard. Dial an extension or telephone number.

When using a headset:

1. Press the **Headset**  button to activate headset mode.
2. No dial tone will be heard. Dial an extension or telephone number.

When you are already on a call:

1. Press the **Hold** button or softkey.
2. Press the **NewCall** softkey.
3. Dial an extension or telephone number.
4. Resume the original call by pressing the **Resume** softkey.

Answering an incoming call

On the handset:

- › Pick up the handset to answer the call.

On the headset:

- › When the headset is connected, press the **Headset**  button to answer the call.

On speakerphone:

- › Press the **Speakerphone**  button to answer the call.

Rejecting an incoming call

Press the **Reject** softkey to immediately send the caller to voicemail.

Ignoring an incoming call

Press the **Silence** softkey to ignore the incoming call.

Note: The caller will continue to hear ringing for the specified amount of time defined in the phone's "No Answer Forward" settings.

Ending a call

On a handset:

- › Option 1: Hang up the handset.
- › Option 2: Press the **More** softkey followed by the **End Call** softkey.



On a headset:

- › Press the **More** softkey followed by the **End Call** softkey.



On speakerphone:

- › Press the **Speakerphone**  button.

Hold

1. To place a current call on hold, press the **Hold**  button or softkey.
2. To resume a call on hold, press the **Hold**  button again or press the **Resume** softkey.

Mute



1. To mute the microphone on an active call, press the **Mute**  button.
2. To unmute the microphone, press the **Mute**  button again.

Voicemail



1. Press the **Messages**  button.
2. Enter your PIN when prompted followed by the # key.

Transferring Calls

Blind transfers:

1. While on a call, press the **Transfer**  button.
2. Dial the desired phone or extension number.
3. Press the **Transfer**  button again.
4. The call is automatically transferred.

Attended (consultative or warm) transfers:

1. While on a call, press the **Transfer**  button.
2. Dial the desired phone or extension number.
3. Wait for the party to answer to announce that you are transferring a call to them.
4. Press the **Transfer**  to transfer the call.

Call waiting

While a new call rings in while you are already on a call, you will hear a beep tone emitted by your phone.

To answer the second call:

1. Press the **Answer** softkey to access that call. The first call will be placed on hold.
2. Once the second call has ended, resume the original call by pressing the **Resume** softkey.

To reject the second call:

- Press the **Reject** softkey to immediately send the caller to voicemail.

Volume adjustment

In-call volume:

- Press the **+** and **-** buttons to raise or lower the volume.

Ringer volume:

- While the phone is not in use, press the **+** and **-** to adjust the ringer volume on the phone.

Speakerphone

While the phone is not in use:

- › Press the **Speakerphone**  button to get dial tone for an outbound call.

While on a call on the handset or headset:

- › Press the **Speakerphone**  button to continue the current call on speakerphone.

While a call on speakerphone is active:

- › Press the **Speakerphone**  button to hang up the current call.

Forwarding calls

1. Press the **Menu** softkey.
2. Press the down arrow to highlight **Features** then press **OK**.
3. Press **OK** while highlighting **Call Forward**.
4. Press the **OK** button or the **Enter** softkey.
5. If **Always Forward** is currently disabled, **Always Forward: Off** will be displayed.
6. Press **OK**, followed by the left or right arrow buttons to enable always forwarding, then press the **Save** softkey.
7. Enter a valid phone number or extension.
8. Press the **OK** button or the **Save** softkey.

Disabling Always Forward:

1. If **Always Forward** is currently enabled, **Always Forward: On** will be displayed.
2. Press the **OK** button or the **Enter** softkey.
3. Use the left or right arrow buttons to disable always forwarding.
4. Press the **OK** button or the **Save** softkey.
5. Set the **Busy Forward** and **No Answer Forward** in the same way.

Speakerphone

While the phone is not in use:

- › Press the **Speakerphone**  button to get dial tone for an outbound call.

While on a call on the handset or headset:

- › Press the **Speakerphone**  button to continue the current call on speakerphone.

While a call on speakerphone is active:

- › Press the **Speakerphone**  button to hang up the current call.

Forwarding calls

1. Press the **Menu** softkey.
2. Press the down arrow to highlight **Features** then press **OK**.
3. Press **OK** while highlighting **Call Forward**.
4. Press the **OK** button or the **Enter** softkey.
5. If **Always Forward** is currently disabled, **Always Forward: Off** will be displayed.
6. Press **OK**, followed by the left or right arrow buttons to enable always forwarding, then press the **Save** softkey.
7. Enter a valid phone number or extension.
8. Press the **OK** button or the **Save** softkey.

Disabling Always Forward:

1. If **Always Forward** is currently enabled, **Always Forward: On** will be displayed.
2. Press the **OK** button or the **Enter** softkey.
3. Use the left or right arrow buttons to disable always forwarding.
4. Press the **OK** button or the **Save** softkey.
5. Set the **Busy Forward** and **No Answer Forward** in the same way.